

BUILDING A

THIS IS A DRAFT PLAN ONLY AND IS SUBJECT TO FINAL SURVEY

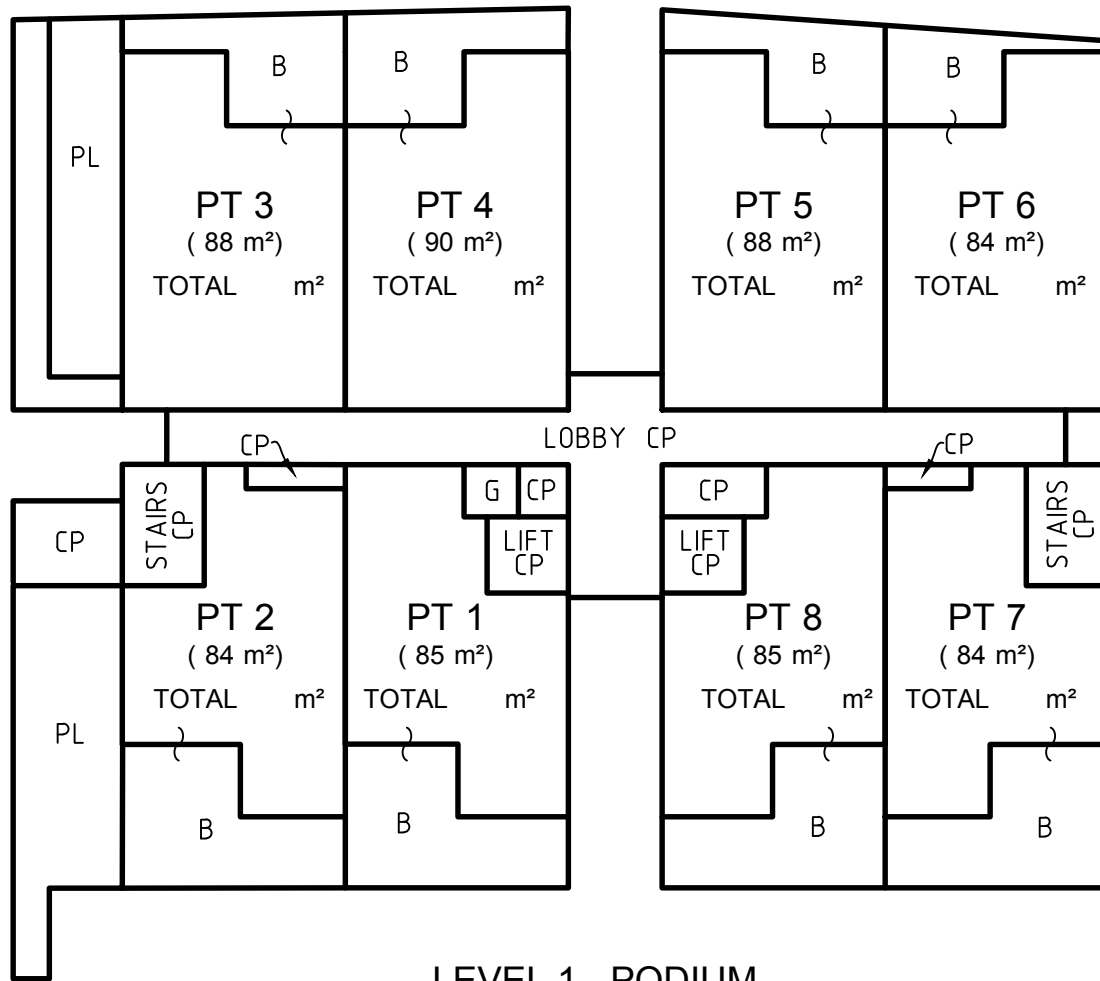

LEVEL 1 - PODIUM

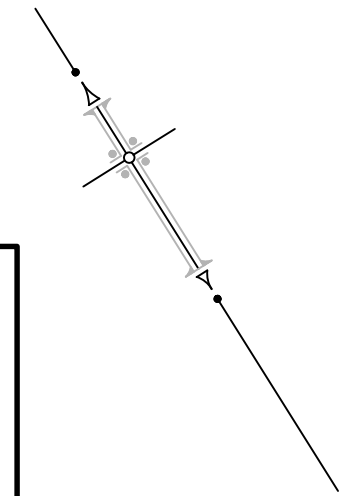
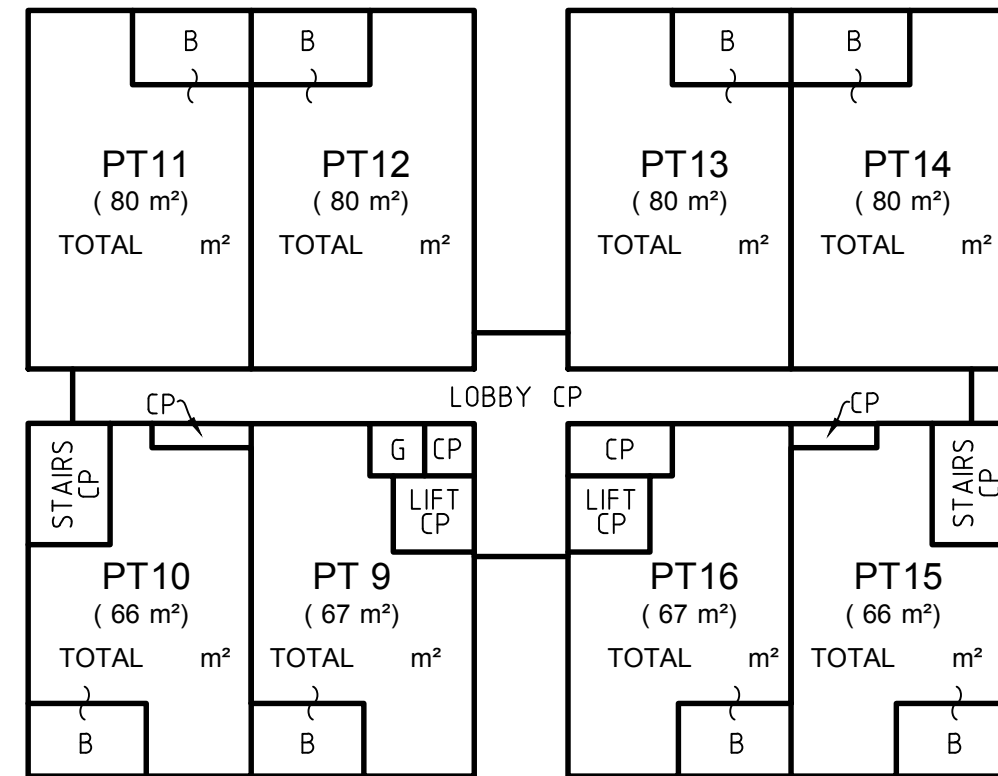

LEVEL 2

NOTES:

- B ~ BALCONY
- CP ~ COMMON PROPERTY
- G ~ GARBAGE CHUTE (CP)
- PL ~ PLANTER (CP)

FOR CLARITY NOT ALL COMMON PROPERTY COLUMNS AND DUCTS HAVE BEEN SHOWN

THE STRATUM OF THE BALCONIES ARE LIMITED IN HEIGHT TO 2.5 ABOVE THEIR RESPECTIVE UPPER HARDSTAND SURFACES UNLESS COVERED WITHIN THIS LIMIT

"THIS IS A DRAFT STRATA PLAN PREPARED FOR CONTRACT PURPOSES ONLY. FINAL DIMENSIONS, AREAS AND LAYOUTS ARE SUBJECT TO SURVEY".

Lot	Unit	Balcooy	Paroog	Store
1	59	26		
2	58	26		
3	72	16		
4	72	18		
5	72	16		
6	72	12		
7	58	26		
8	59	26		

Lot	Unit	Balcooy	Paroog	Store
9	59	8		
10	58	8		
11	72	8		
12	72	8		
13	72	8		
14	72	8		
15	58	8		
16	59	8		

SURVEYOR
Name: JOSEPH MONARDO
Date of Survey: -
Surveyor's Reference: 44204 - 44595SP

PLAN OF SUBDIVISION OF LOT 1 IN DP [] [] [] [] [] [] [] []
(FORMERLY PART OF LOT 100 DP700822 AND LOT 3 DP248832)

LGA: BAYSIDE
Locality: EASTLAKES
Reduction Ratio 1: 250
Lengths are in metres.



SP DRAFT
ISSUE F : 29-05-2018

BUILDING A

THIS IS A DRAFT PLAN ONLY AND IS SUBJECT TO FINAL SURVEY

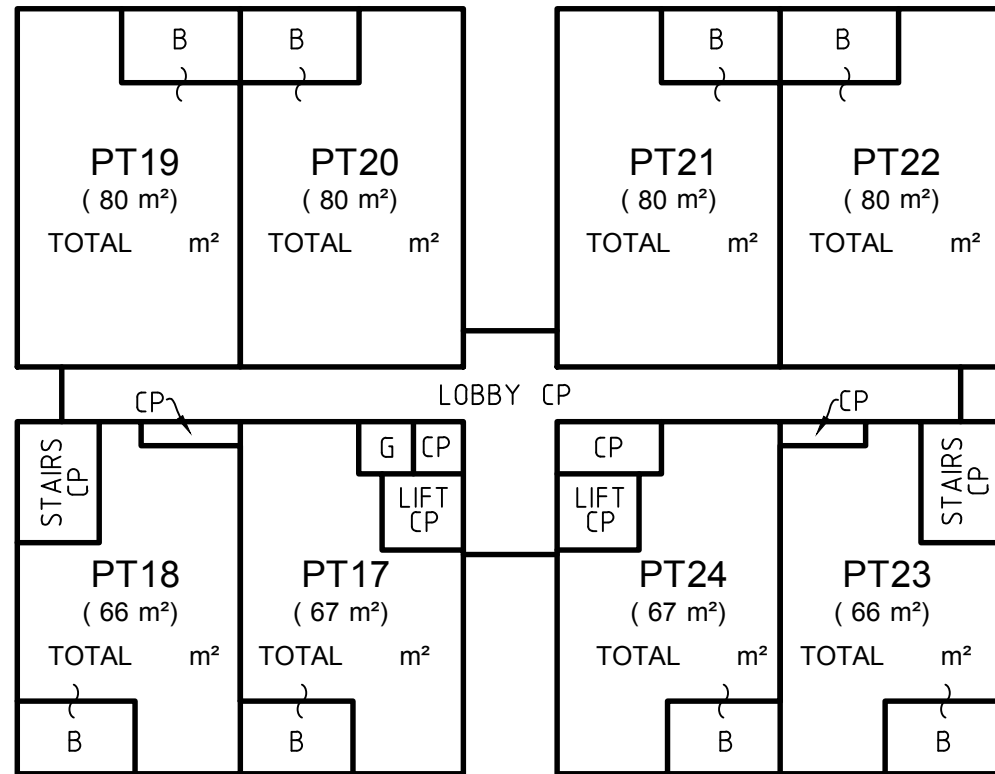
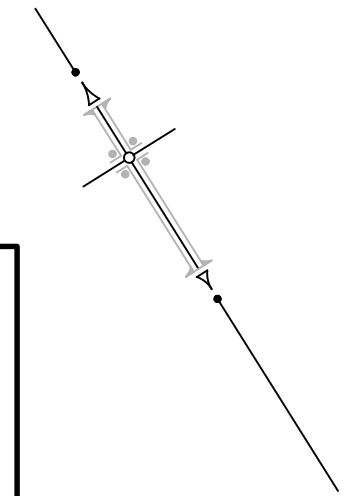

LEVEL 3

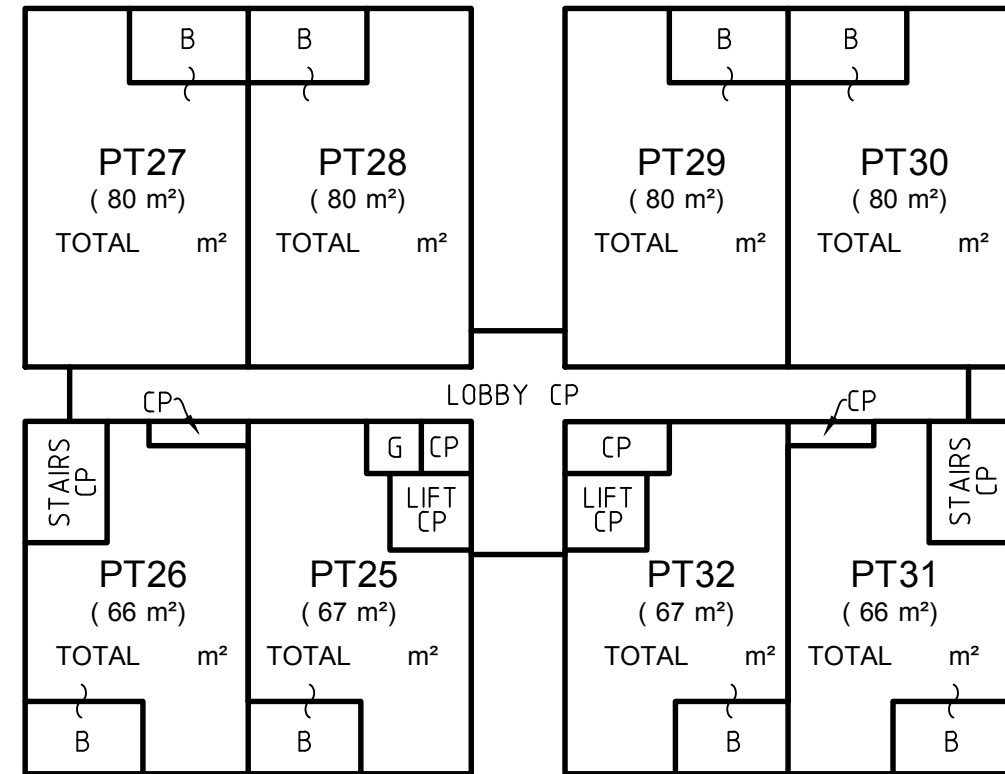

**LEVEL 4
(MARKETING LEVEL 5)**

NOTES:

- B ~ BALCONY
- CP ~ COMMON PROPERTY
- G ~ GARBAGE CHUTE (CP)

FOR CLARITY NOT ALL COMMON PROPERTY COLUMNS AND DUCTS HAVE BEEN SHOWN

THE STRATUM OF THE BALCONIES ARE LIMITED IN HEIGHT TO 2.5 ABOVE THEIR RESPECTIVE UPPER HARDSTAND SURFACES UNLESS COVERED WITHIN THIS LIMIT

"THIS IS A DRAFT STRATA PLAN PREPARED FOR CONTRACT PURPOSES ONLY. FINAL DIMENSIONS, AREAS AND LAYOUTS ARE SUBJECT TO SURVEY".

Lot	Unit	Balcooy	Paroog	Store
17	59	8		
18	58	8		
19	72	8		
20	72	8		
21	72	8		
22	72	8		
23	58	8		
24	59	8		

Lot	Unit	Balcooy	Paroog	Store
25	59	8		
26	58	8		
27	72	8		
28	72	8		
29	72	8		
30	72	8		
31	58	8		
32	59	8		

SURVEYOR
Name: JOSEPH MONARDO
Date of Survey: -
Surveyor's Reference: 44204 - 44595SP

PLAN OF SUBDIVISION OF LOT 1 IN DP [] [] [] [] [] [] [] []
(FORMERLY PART OF LOT 100 DP700822 AND LOT 3 DP248832)

LGA: BAYSIDE
Locality: EASTLAKES
Reduction Ratio 1: 250
Lengths are in metres.



SP DRAFT
ISSUE F : 29-05-2018

BUILDING A

THIS IS A DRAFT PLAN ONLY AND IS SUBJECT TO FINAL SURVEY

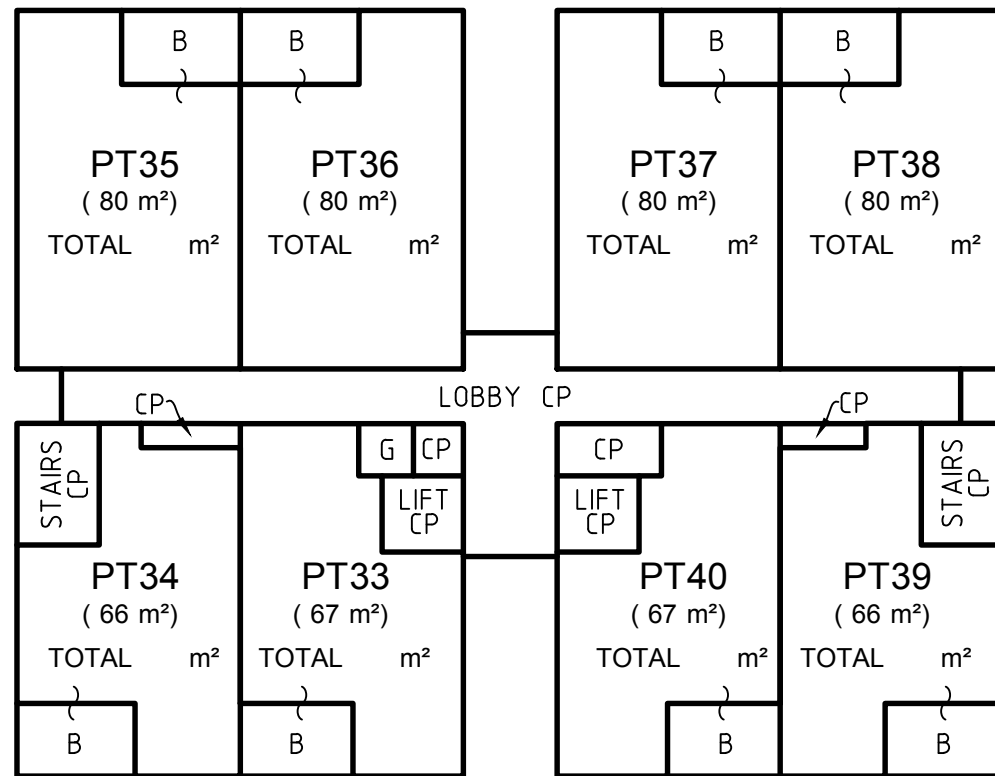
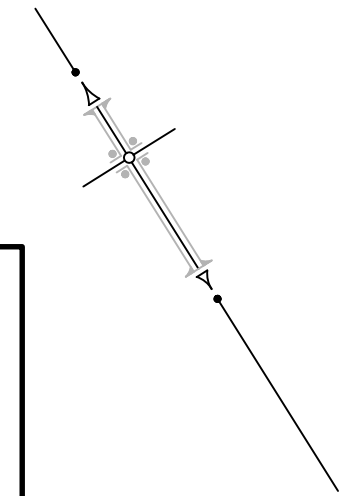

LEVEL 5
(MARKETING LEVEL 6)

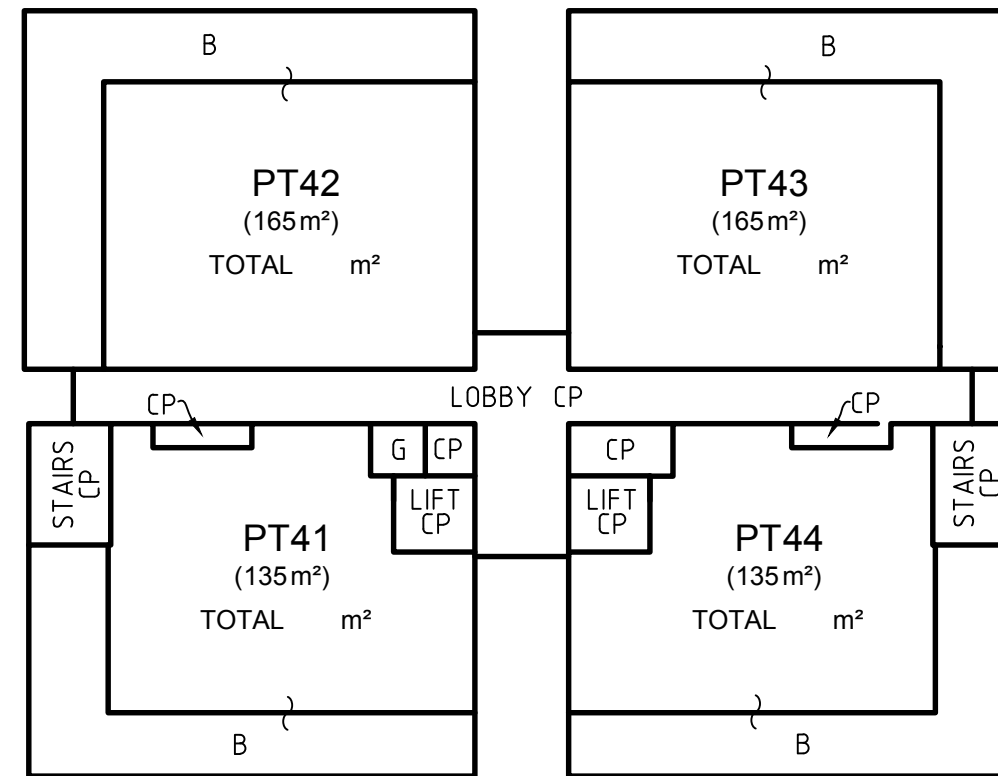

LEVEL 6
(MARKETING LEVEL 7)

NOTES:

- B ~ BALCONY
- CP ~ COMMON PROPERTY
- G ~ GARBAGE CHUTE (CP)

FOR CLARITY NOT ALL COMMON PROPERTY COLUMNS AND DUCTS HAVE BEEN SHOWN

THE STRATUM OF THE BALCONIES ARE LIMITED IN HEIGHT TO 2.5 ABOVE THEIR RESPECTIVE UPPER HARDSTAND SURFACES UNLESS COVERED WITHIN THIS LIMIT

"THIS IS A DRAFT STRATA PLAN PREPARED FOR CONTRACT PURPOSES ONLY. FINAL DIMENSIONS, AREAS AND LAYOUTS ARE SUBJECT TO SURVEY".

Lot	Unit	Balcooy	Paroog	Store
33	59	8		
34	58	8		
35	72	8		
36	72	8		
37	72	8		
38	72	8		
39	58	8		
40	59	8		

Lot	Unit	Balcooy	Paroog	Store
41	90	45		
42	110	55		
43	110	55		
44	90	45		

SURVEYOR
Name: JOSEPH MONARDO
Date of Survey: -
Surveyor's Reference: 44204 - 44595SP

PLAN OF SUBDIVISION OF LOT 1 IN DP [] [] [] [] [] []
(FORMERLY PART OF LOT 100 DP700822 AND LOT 3 DP248832)

LGA: BAYSIDE
Locality: EASTLAKES
Reduction Ratio 1: 250
Lengths are in metres.



SP DRAFT
ISSUE F : 29-05-2018

BUILDING B
LEVEL 1 - PODIUM

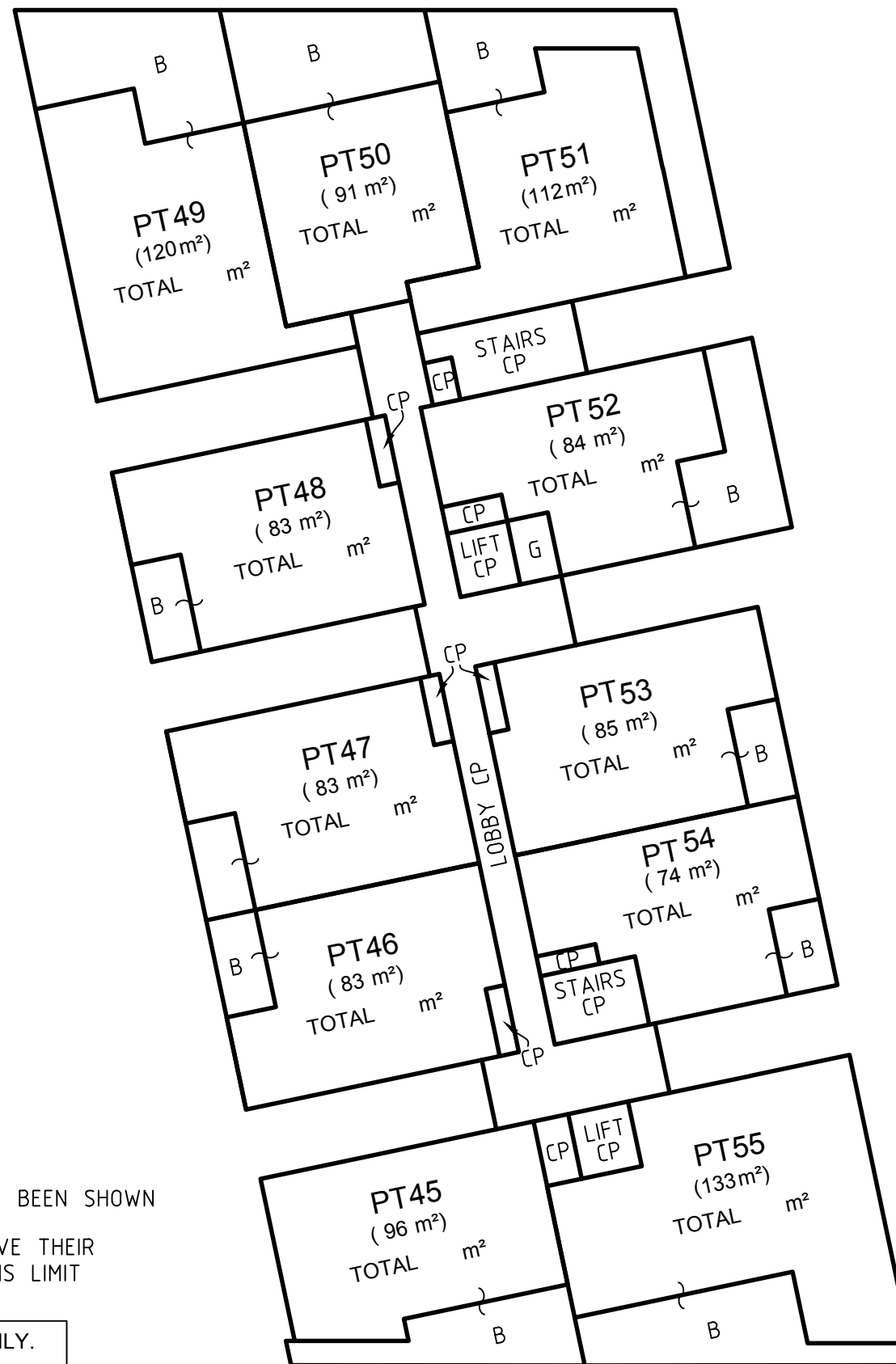

THIS IS A DRAFT PLAN ONLY AND IS SUBJECT TO FINAL SURVEY

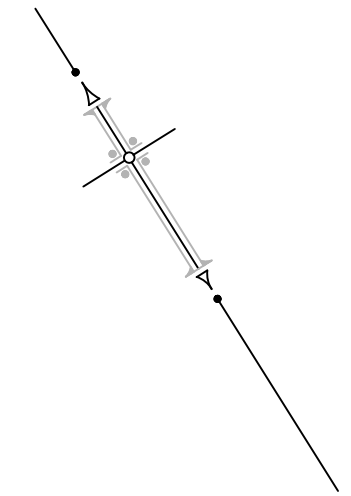

NOTES:

- B ~ BALCONY
- CP ~ COMMON PROPERTY
- G ~ GARBAGE CHUTE (CP)
- PL ~ PLANTER (CP)

FOR CLARITY NOT ALL COMMON PROPERTY COLUMNS AND DUCTS HAVE BEEN SHOWN

THE STRATUM OF THE BALCONIES ARE LIMITED IN HEIGHT TO 2.5 ABOVE THEIR RESPECTIVE UPPER HARDSTAND SURFACES UNLESS COVERED WITHIN THIS LIMIT

"THIS IS A DRAFT STRATA PLAN PREPARED FOR CONTRACT PURPOSES ONLY. FINAL DIMENSIONS, AREAS AND LAYOUTS ARE SUBJECT TO SURVEY".

Lot	Unit	Balcoy	Paroing	Store
45	74	22		
46	75	8		
47	75	8		
48	75	8		
49	87	33		
50	62	29		
51	76	36		
52	66	18		
53	77	8		
54	67	7		
55	103	30		

SURVEYOR
Name: JOSEPH MONARDO
Date of Survey: -
Surveyor's Reference: 44204 - 44595SP

PLAN OF SUBDIVISION OF LOT 1 IN DP [] [] [] [] [] [] [] []
(FORMERLY PART OF LOT 100 DP700822 AND LOT 3 DP248832)

LGA: BAYSIDE
Locality: EASTLAKES
Reduction Ratio 1: 250
Lengths are in metres.



SP DRAFT
ISSUE F : 29-05-2018

BUILDING B
LEVEL 2

THIS IS A DRAFT PLAN ONLY AND IS
SUBJECT TO FINAL SURVEY

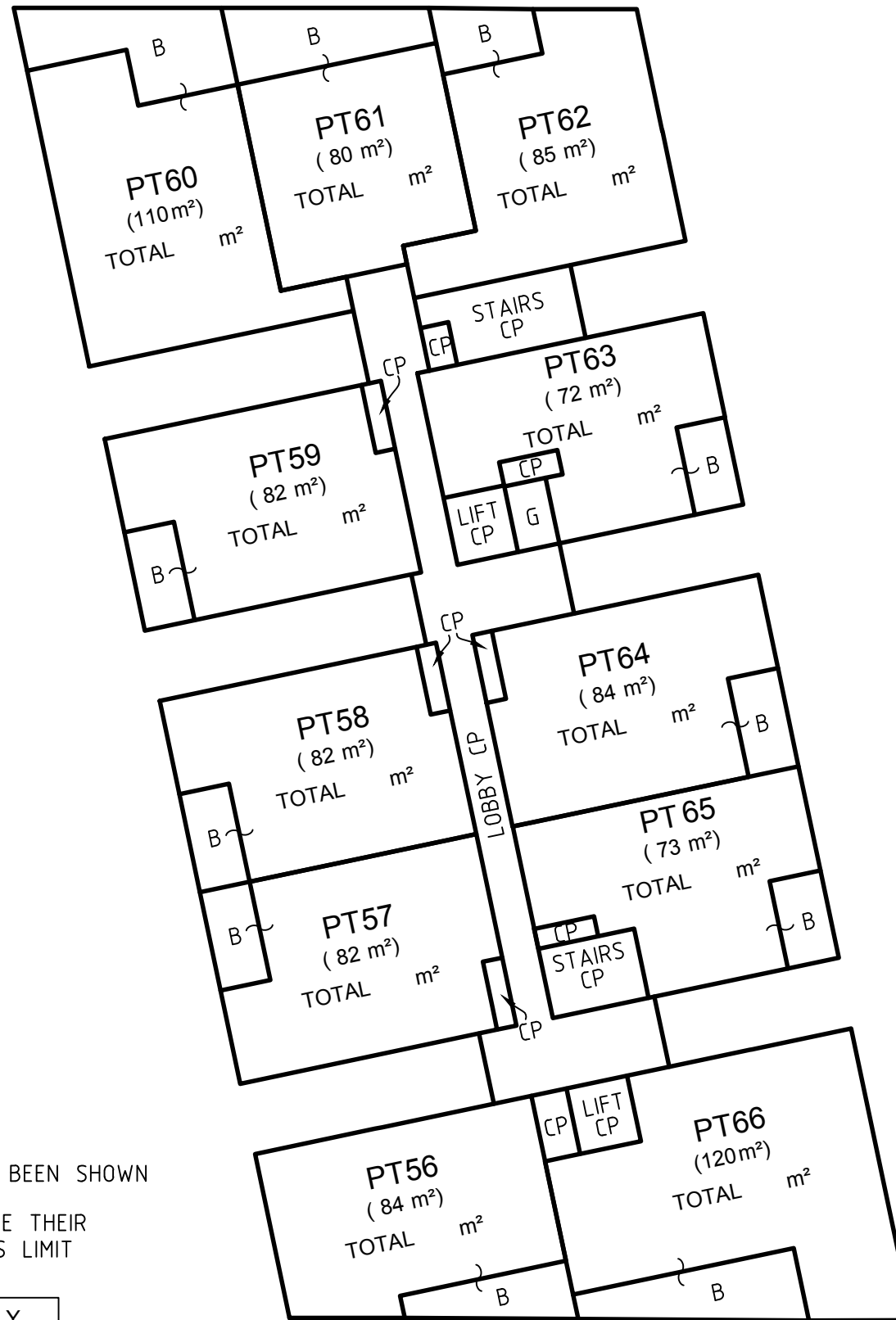
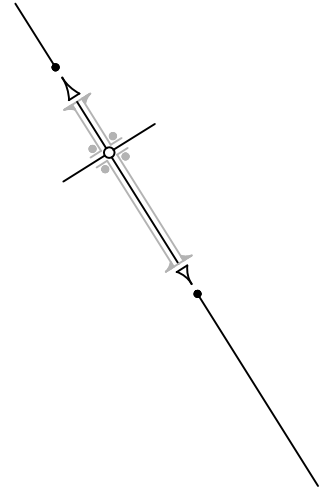

NOTES:

- B ~ BALCONY
- CP ~ COMMON PROPERTY
- G ~ GARBAGE CHUTE (CP)

FOR CLARITY NOT ALL COMMON PROPERTY COLUMNS AND DUCTS HAVE BEEN SHOWN

THE STRATUM OF THE BALCONIES ARE LIMITED IN HEIGHT TO 2.5 ABOVE THEIR RESPECTIVE UPPER HARDSTAND SURFACES UNLESS COVERED WITHIN THIS LIMIT

"THIS IS A DRAFT STRATA PLAN PREPARED FOR CONTRACT PURPOSES ONLY. FINAL DIMENSIONS, AREAS AND LAYOUTS ARE SUBJECT TO SURVEY".

Lot	Unit	Balcoy	Paroing	Store
56	74	10		
57	75	7		
58	75	7		
59	75	7		
60	87	23		
61	62	18		
62	76	9		
63	66	6		
64	77	7		
65	67	6		
66	103	17		

SURVEYOR
Name: JOSEPH MONARDO
Date of Survey: -
Surveyor's Reference: 44204 - 44595SP

PLAN OF SUBDIVISION OF LOT 1 IN DP [] [] [] [] [] []
(FORMERLY PART OF LOT 100 DP700822 AND LOT 3 DP248832)

LGA: BAYSIDE
Locality: EASTLAKES
Reduction Ratio 1: 250
Lengths are in metres.



SP DRAFT
ISSUE F : 29-05-2018

BUILDING B
LEVEL 3

THIS IS A DRAFT PLAN ONLY AND IS
SUBJECT TO FINAL SURVEY

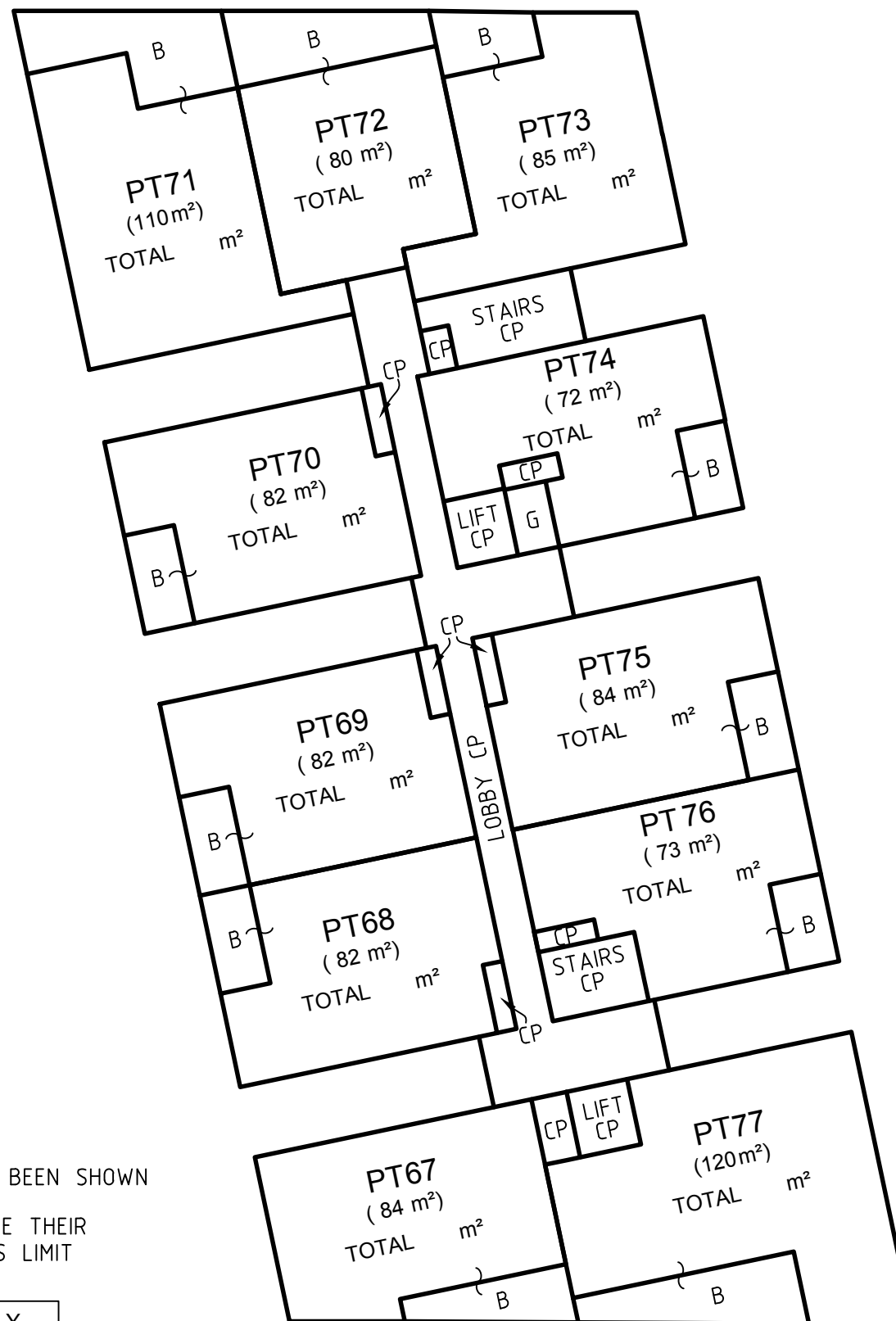
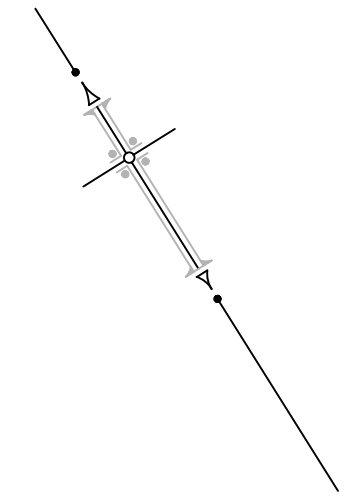

NOTES:

- B ~ BALCONY
- CP ~ COMMON PROPERTY
- G ~ GARBAGE CHUTE (CP)

FOR CLARITY NOT ALL COMMON PROPERTY COLUMNS AND DUCTS HAVE BEEN SHOWN

THE STRATUM OF THE BALCONIES ARE LIMITED IN HEIGHT TO 2.5 ABOVE THEIR RESPECTIVE UPPER HARDSTAND SURFACES UNLESS COVERED WITHIN THIS LIMIT

"THIS IS A DRAFT STRATA PLAN PREPARED FOR CONTRACT PURPOSES ONLY. FINAL DIMENSIONS, AREAS AND LAYOUTS ARE SUBJECT TO SURVEY".

Lot	Unit	Balcoy	Paroing	Store
67	74	10		
68	75	7		
69	75	7		
70	75	7		
71	87	23		
72	62	18		
73	76	9		
74	66	6		
75	77	7		
76	67	6		
77	103	17		

SURVEYOR
Name: JOSEPH MONARDO
Date of Survey: -
Surveyor's Reference: 44204 - 44595SP

PLAN OF SUBDIVISION OF LOT 1 IN DP [] [] [] [] [] [] [] []
(FORMERLY PART OF LOT 100 DP700822 AND LOT 3 DP248832)

LGA: BAYSIDE
Locality: EASTLAKES
Reduction Ratio 1: 250
Lengths are in metres.



SP DRAFT
ISSUE F : 29-05-2018

BUILDING B

LEVEL 4

(MARKETING LEVEL 5)

THIS IS A DRAFT PLAN ONLY AND IS SUBJECT TO FINAL SURVEY

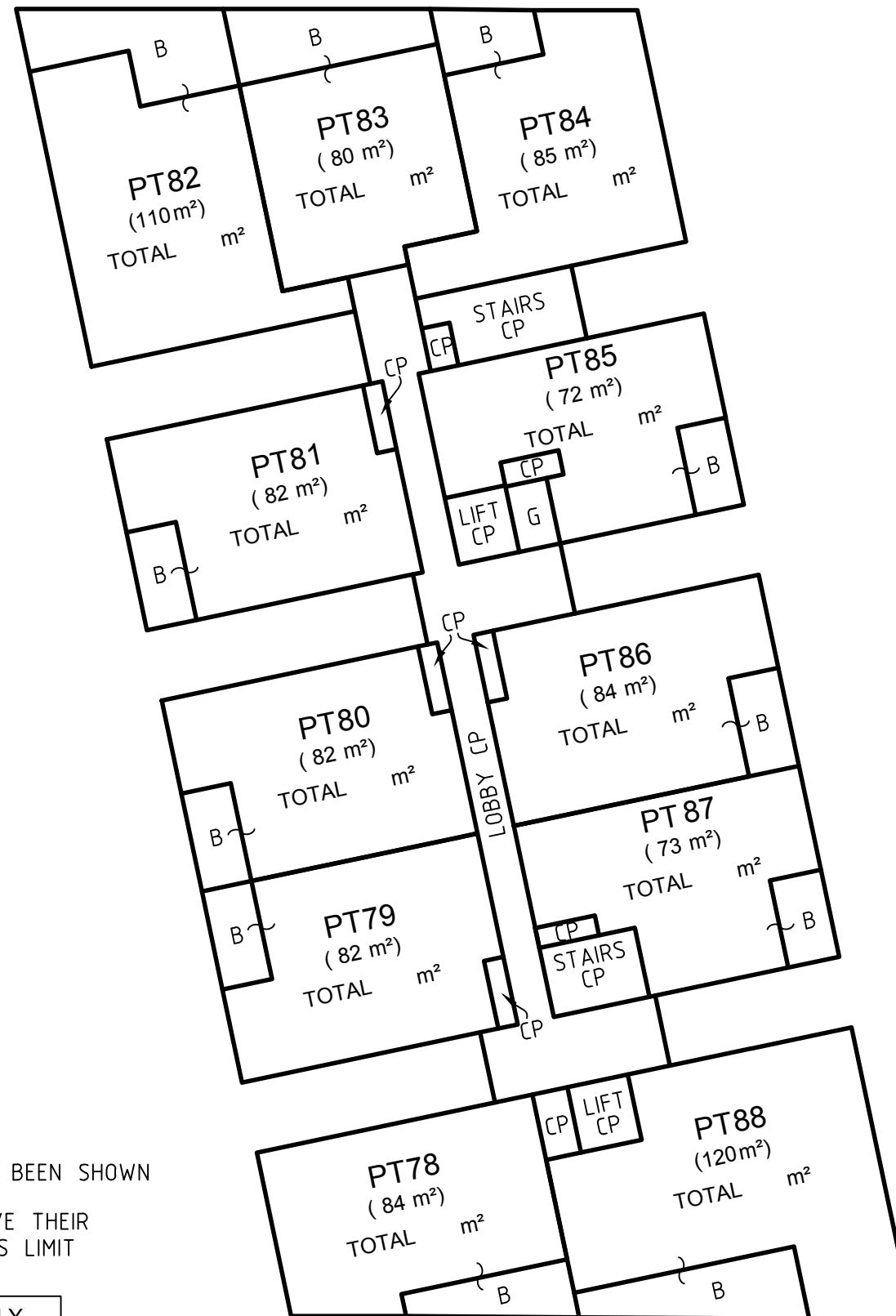

NOTES:

- B ~ BALCONY
- CP ~ COMMON PROPERTY
- G ~ GARBAGE CHUTE (CP)

FOR CLARITY NOT ALL COMMON PROPERTY COLUMNS AND DUCTS HAVE BEEN SHOWN

THE STRATUM OF THE BALCONIES ARE LIMITED IN HEIGHT TO 2.5 ABOVE THEIR RESPECTIVE UPPER HARDSTAND SURFACES UNLESS COVERED WITHIN THIS LIMIT

"THIS IS A DRAFT STRATA PLAN PREPARED FOR CONTRACT PURPOSES ONLY. FINAL DIMENSIONS, AREAS AND LAYOUTS ARE SUBJECT TO SURVEY".

Lot	Unit	Balcoy	Paroing	Store
78	74	10		
79	75	7		
80	75	7		
81	75	7		
82	87	23		
83	62	18		
84	76	9		
85	66	6		
86	77	7		
87	67	6		
88	103	17		

SURVEYOR
 Name: JOSEPH MONARDO
 Date of Survey: -
 Surveyor's Reference: 44204 - 44595SP

PLAN OF SUBDIVISION OF LOT 1 IN DP [] [] [] [] [] []
 (FORMERLY PART OF LOT 100 DP700822 AND LOT 3 DP248832)

LGA: BAYSIDE
 Locality: EASTLAKES
 Reduction Ratio 1: 250
 Lengths are in metres.



SP DRAFT
 ISSUE F : 29-05-2018

BUILDING B

LEVEL 5

(MARKETING LEVEL 6)

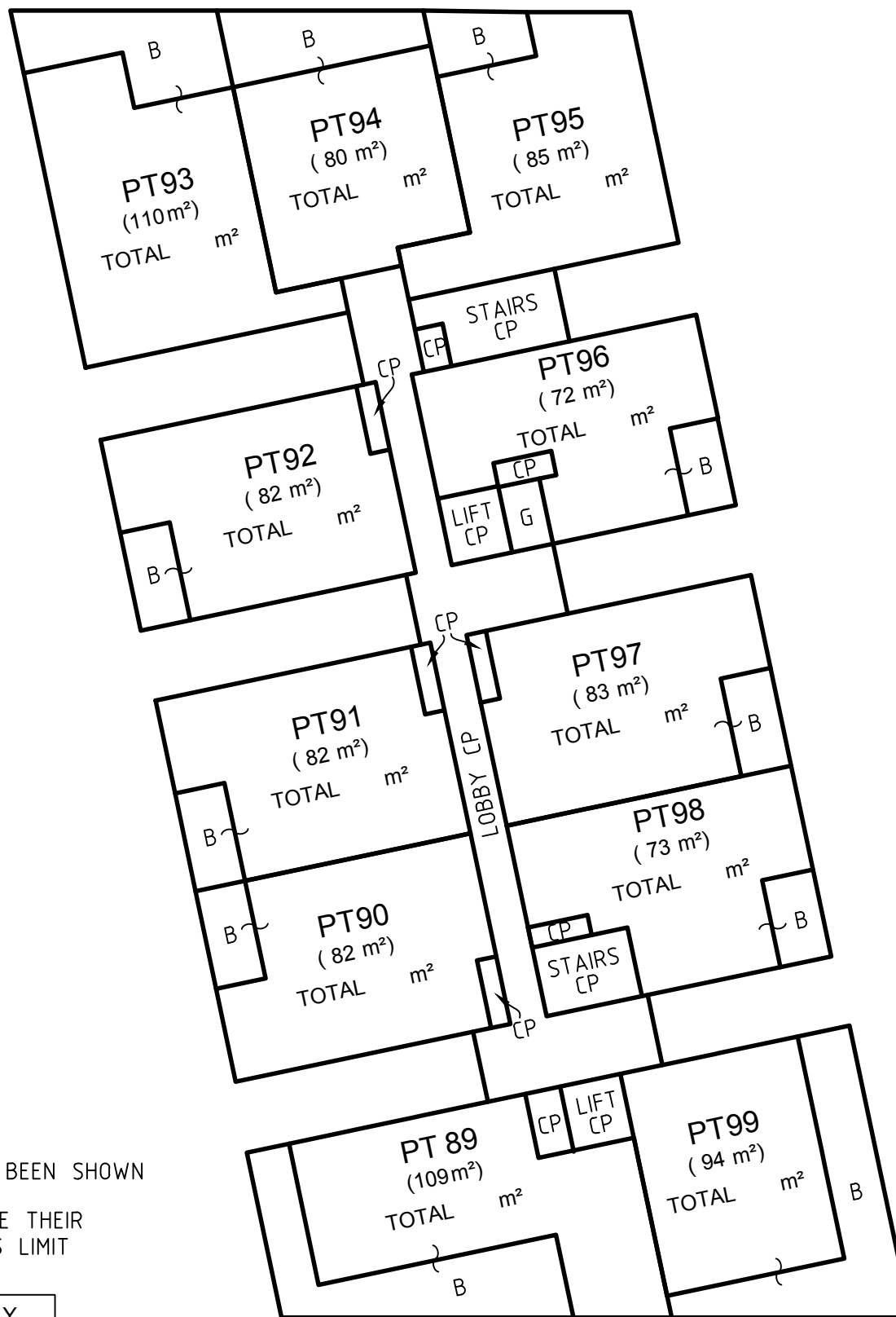

THIS IS A DRAFT PLAN ONLY AND IS SUBJECT TO FINAL SURVEY

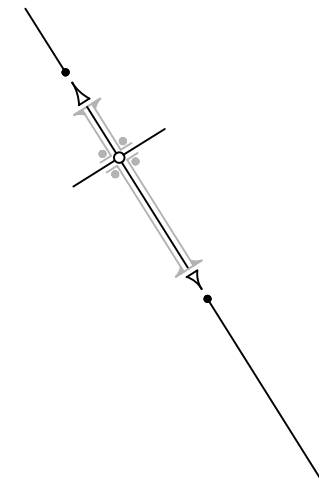

NOTES:

- B ~ BALCONY
- CP ~ COMMON PROPERTY
- G ~ GARBAGE CHUTE (CP)

FOR CLARITY NOT ALL COMMON PROPERTY COLUMNS AND DUCTS HAVE BEEN SHOWN

THE STRATUM OF THE BALCONIES ARE LIMITED IN HEIGHT TO 2.5 ABOVE THEIR RESPECTIVE UPPER HARDSTAND SURFACES UNLESS COVERED WITHIN THIS LIMIT

"THIS IS A DRAFT STRATA PLAN PREPARED FOR CONTRACT PURPOSES ONLY. FINAL DIMENSIONS, AREAS AND LAYOUTS ARE SUBJECT TO SURVEY".

Lot	Unit	Balcoy	Paroing	Store
89	77	32		
90	75	7		
91	75	7		
92	75	7		
93	87	23		
94	62	18		
95	76	9		
96	66	6		
97	76	7		
98	67	6		
99	62	32		

SURVEYOR
 Name: JOSEPH MONARDO
 Date of Survey: -
 Surveyor's Reference: 44204 - 44595SP

PLAN OF SUBDIVISION OF LOT 1 IN DP [] [] [] [] [] [] [] []
 (FORMERLY PART OF LOT 100 DP700822 AND LOT 3 DP248832)

LGA: BAYSIDE
 Locality : EASTLAKES
 Reduction Ratio 1: 250
 Lengths are in metres.



SP DRAFT
 ISSUE F : 29-05-2018

BUILDING B

LEVEL 6

(MARKETING LEVEL 7)

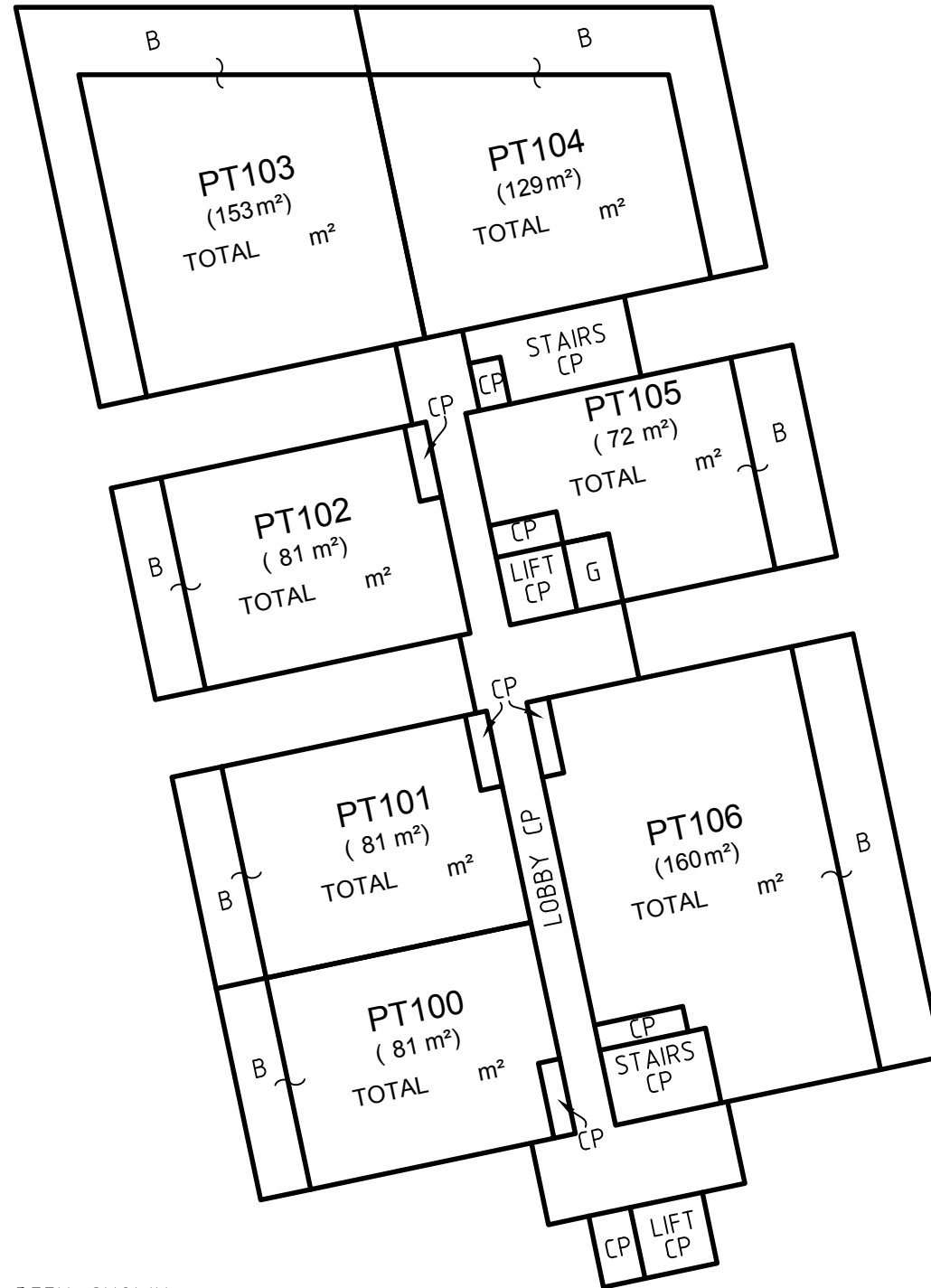

THIS IS A DRAFT PLAN ONLY AND IS SUBJECT TO FINAL SURVEY

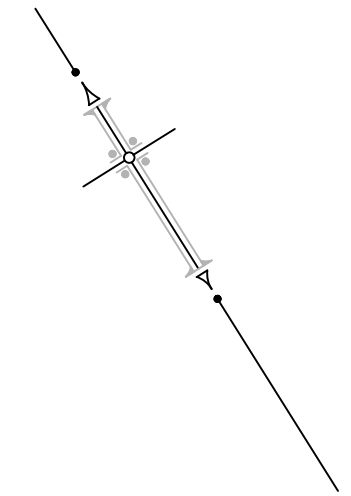

NOTES:

- B ~ BALCONY
- CP ~ COMMON PROPERTY
- G ~ GARBAGE CHUTE (CP)

FOR CLARITY NOT ALL COMMON PROPERTY COLUMNS AND DUCTS HAVE BEEN SHOWN

THE STRATUM OF THE BALCONIES ARE LIMITED IN HEIGHT TO 2.5 ABOVE THEIR RESPECTIVE UPPER HARDSTAND SURFACES UNLESS COVERED WITHIN THIS LIMIT

"THIS IS A DRAFT STRATA PLAN PREPARED FOR CONTRACT PURPOSES ONLY. FINAL DIMENSIONS, AREAS AND LAYOUTS ARE SUBJECT TO SURVEY".

Lot	Unit	Balcony	Parking	Store
100	67	14		
101	67	14		
102	67	14		
103	107	46		
104	87	42		
105	58	14		
106	131	29		

SURVEYOR
 Name: JOSEPH MONARDO
 Date of Survey: -
 Surveyor's Reference: 44204 - 44595SP

PLAN OF SUBDIVISION OF LOT 1 IN DP [] [] [] [] [] [] [] []
 (FORMERLY PART OF LOT 100 DP700822 AND LOT 3 DP248832)

LGA: BAYSIDE
 Locality: EASTLAKES
 Reduction Ratio 1: 250
 Lengths are in metres.



SP DRAFT
 ISSUE F : 29-05-2018

BUILDING C

THIS IS A DRAFT PLAN ONLY AND IS SUBJECT TO FINAL SURVEY

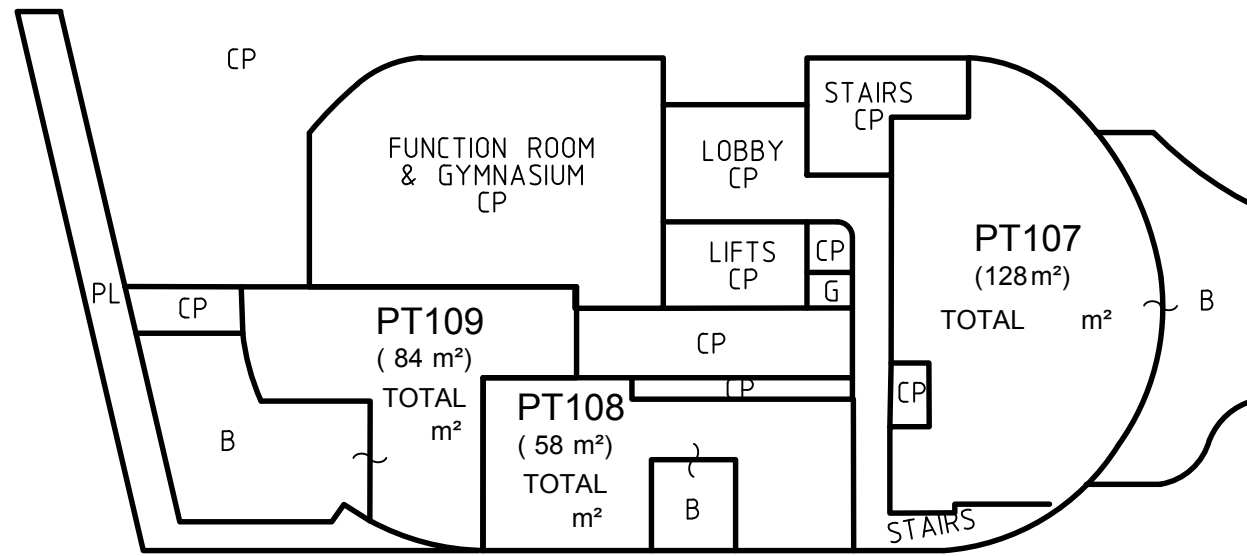

LEVEL 1 - PODIUM

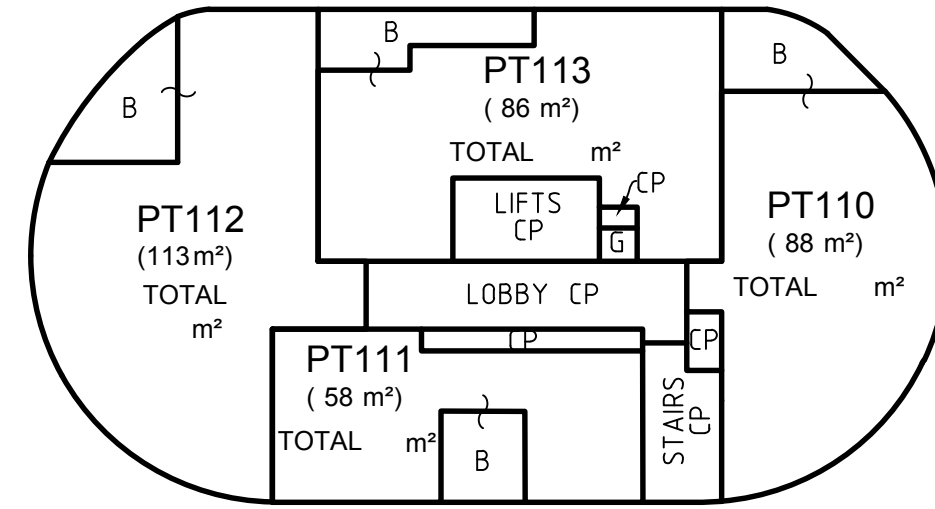

LEVEL 2

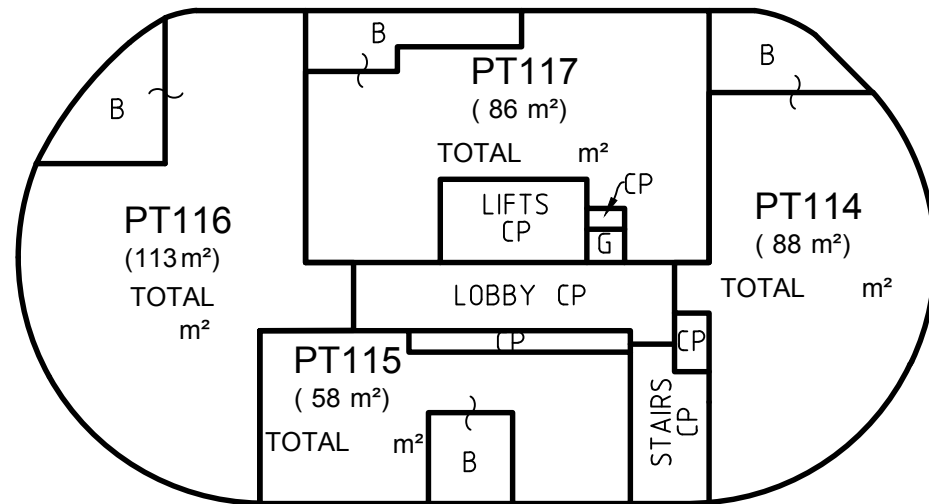

LEVEL 3

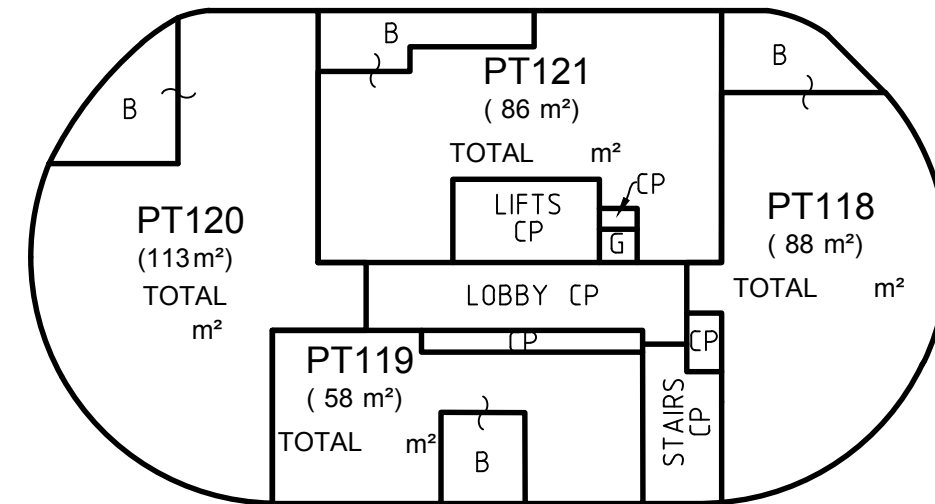

**LEVEL 4
(MARKETING LEVEL 5)**

NOTES:

- B ~ BALCONY
- CP ~ COMMON PROPERTY
- G ~ GARBAGE CHUTE (CP)
- PL ~ PLANTER (CP)

FOR CLARITY NOT ALL COMMON PROPERTY COLUMNS AND DUCTS HAVE BEEN SHOWN

THE STRATUM OF THE BALCONIES ARE LIMITED IN HEIGHT TO 2.5 ABOVE THEIR RESPECTIVE UPPER HARDSTAND SURFACES UNLESS COVERED WITHIN THIS LIMIT

"THIS IS A DRAFT STRATA PLAN PREPARED FOR CONTRACT PURPOSES ONLY. FINAL DIMENSIONS, AREAS AND LAYOUTS ARE SUBJECT TO SURVEY".

Lot	Unit	Balcooy	Paroog	Store
107	95	33		
108	50	8		
109	50	34		
110	79	9		
111	50	8		
112	102	11		
113	77	9		

Lot	Unit	Balcooy	Paroog	Store
114	79	9		
115	50	8		
116	102	11		
117	77	9		
118	79	9		
119	50	8		
120	102	11		
121	77	9		

SURVEYOR
Name: JOSEPH MONARDO
Date of Survey: -
Surveyor's Reference: 44204 - 44595SP

PLAN OF SUBDIVISION OF LOT 1 IN DP [] [] [] [] [] [] [] []
(FORMERLY PART OF LOT 100 DP700822 AND LOT 3 DP248832)

LGA: BAYSIDE
Locality: EASTLAKES
Reduction Ratio 1: 250
Lengths are in metres.



SP DRAFT
ISSUE F : 29-05-2018

BUILDING C

THIS IS A DRAFT PLAN ONLY AND IS SUBJECT TO FINAL SURVEY

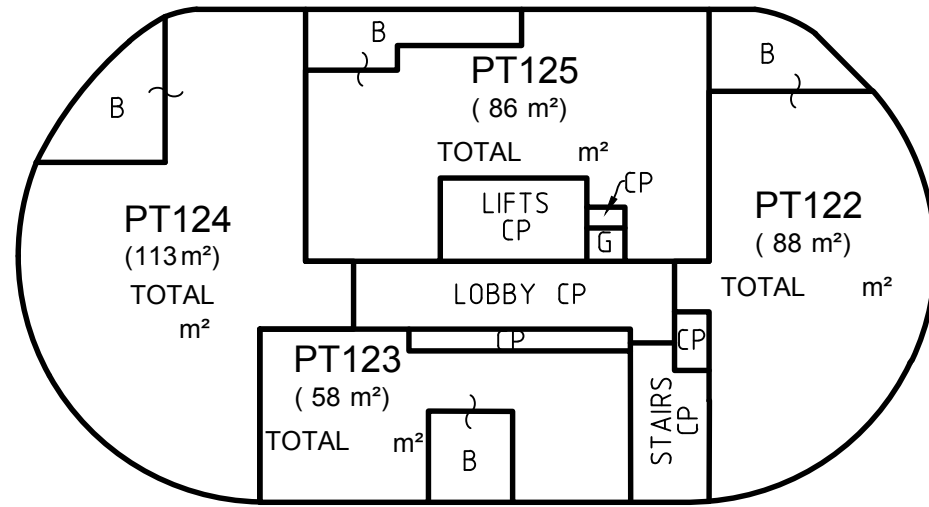

LEVEL 5
(MARKETING LEVEL 6)

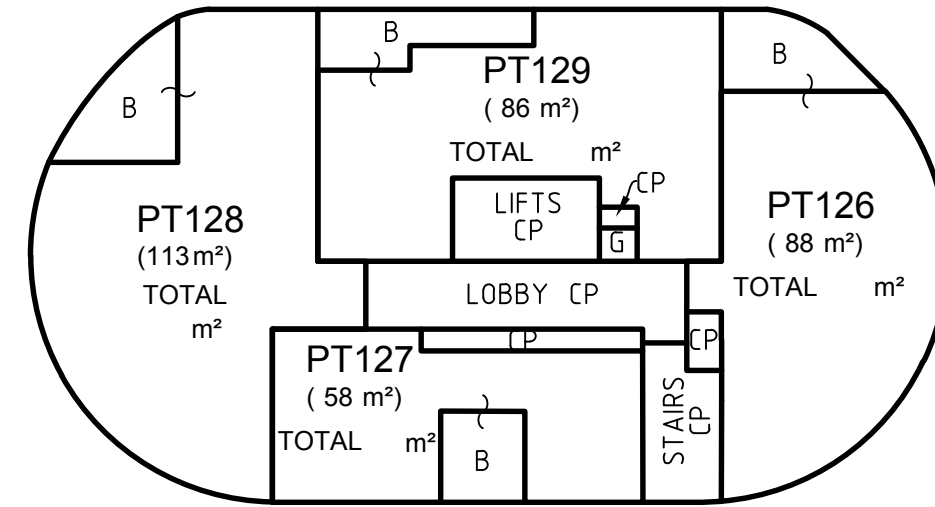

LEVEL 6
(MARKETING LEVEL 7)

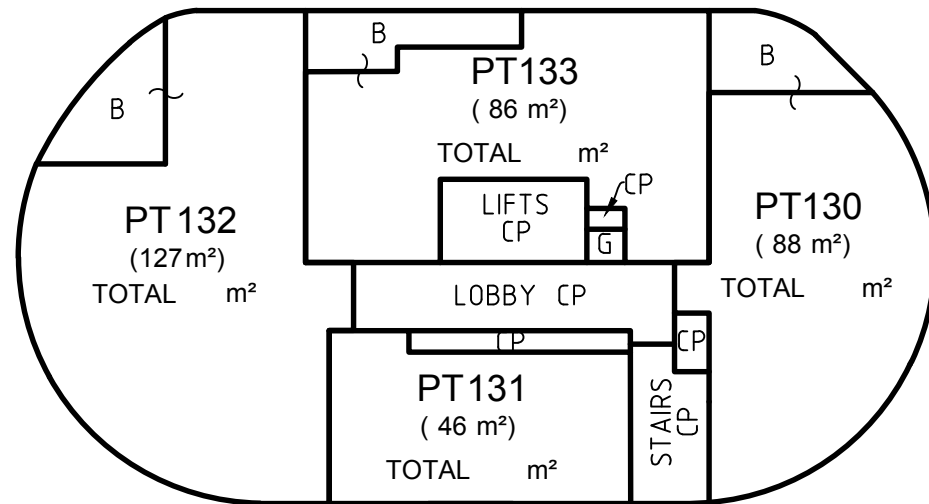

LEVEL 7
(MARKETING LEVEL 8)

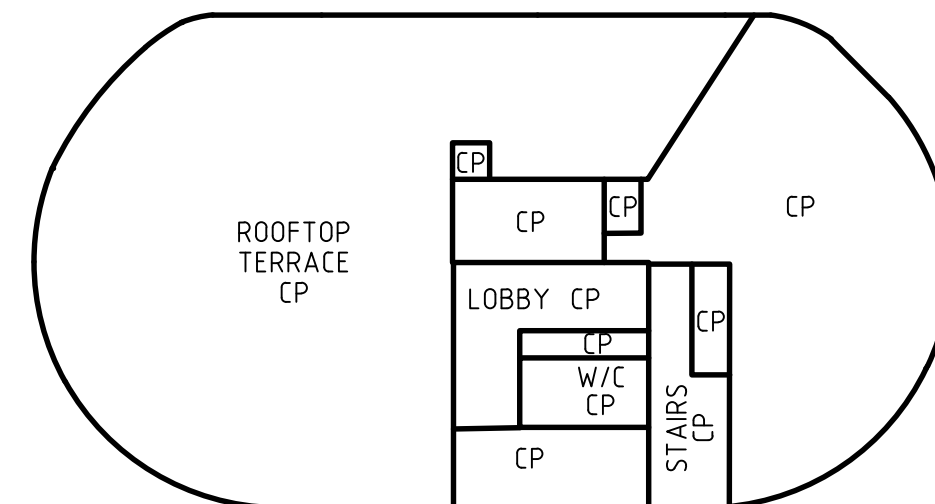

LEVEL 8
(MARKETING LEVEL 9)

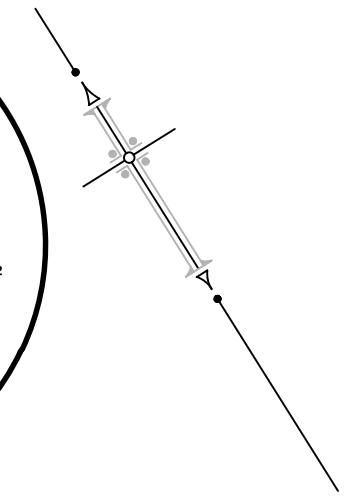

NOTES:

- B ~ BALCONY
- CP ~ COMMON PROPERTY
- G ~ GARBAGE CHUTE (CP)

FOR CLARITY NOT ALL COMMON PROPERTY COLUMNS AND DUCTS HAVE BEEN SHOWN

THE STRATUM OF THE BALCONIES ARE LIMITED IN HEIGHT TO 2.5 ABOVE THEIR RESPECTIVE UPPER HARDSTAND SURFACES UNLESS COVERED WITHIN THIS LIMIT

"THIS IS A DRAFT STRATA PLAN PREPARED FOR CONTRACT PURPOSES ONLY. FINAL DIMENSIONS, AREAS AND LAYOUTS ARE SUBJECT TO SURVEY".

Lot	Unit	Balcooy	Paroog	Store
122	79	9		
123	50	8		
124	102	11		
125	77	9		
126	79	9		
127	50	8		
128	102	11		
129	77	9		

Lot	Unit	Balcooy	Paroog	Store
130	79	9		
131	46	0		
132	116	11		
133	77	9		

SURVEYOR
Name: JOSEPH MONARDO
Date of Survey: -
Surveyor's Reference: 44204 - 44595SP

PLAN OF SUBDIVISION OF LOT 1 IN DP [] [] [] [] [] [] [] []
(FORMERLY PART OF LOT 100 DP700822 AND LOT 3 DP248832)

LGA: BAYSIDE
Locality: EASTLAKES
Reduction Ratio 1: 250
Lengths are in metres.



SP DRAFT
ISSUE F : 29-05-2018